

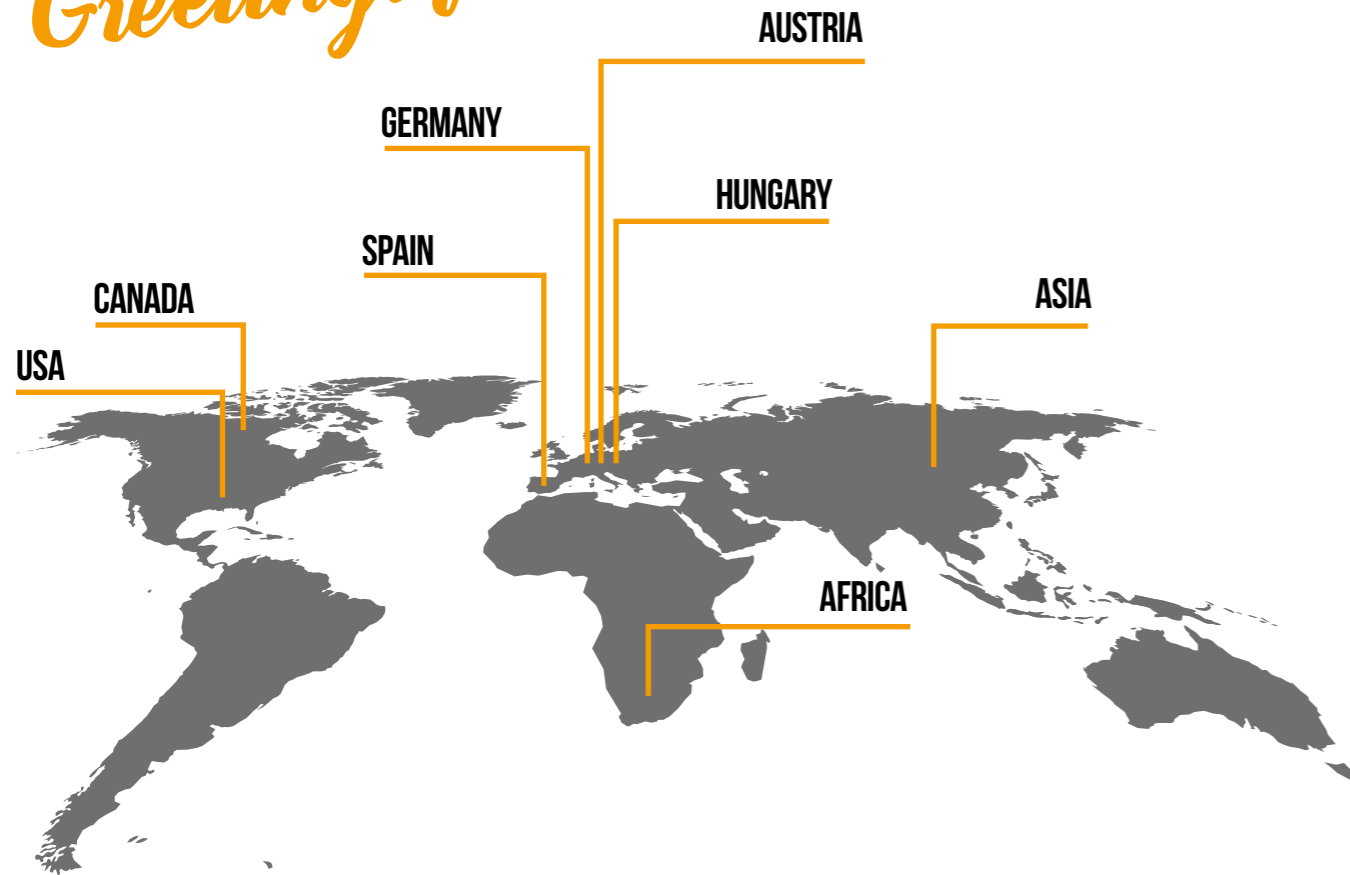

**CAKE INSPIRATION**  
**FROM AROUND**  
**THE WORLD**  
**WITH DREIDOPPEL**  
**FLAVOUR VARIETY**



# Greetings from



## DIFFERENT COUNTRIES — DIFFERENT CAKES!

Come with us on an inspiring journey of indulgence to the panorama of cakes from our European neighbours, or from the far corners of the world. We have classical cake recipes for you, morning and with a new twist, so that you can present your customers and guests with fresh ideas in your range of cakes.

We have written these recipes both as classic cakes and as trendy single por-

tions in order to provide you with even more diversity in your product range. Now you can conjure up customised variety in your showcase with just one mixture.

Our extensive range of many flavourings and pastry pastes will put the typical tastes of each country in baked goods in the blink of an eye, and will delight customers with a delicious vacation feeling.

You will find more information about our products and lots of inspiration for cakes at [www.dreidoppel.de](http://www.dreidoppel.de).

### CONTENTS

<b>GREETINGS FROM AUSTRIA</b> INSPIRATION: APPLE STRUDEL	12
<b>GREETINGS FROM THE USA</b> INSPIRATION: BANANA FOSTER	13
<b>GREETINGS FROM SPAIN</b> INSPIRATION: SAN MARCOS CAKE	14

<b>GREETINGS FROM CANADA</b> INSPIRATION: S'MORES	15
<b>GREETINGS FROM ASIA</b> INSPIRATION: JAPANESE CHEESECAKE	24
<b>GREETINGS FROM GERMANY</b> INSPIRATION: BLACK FOREST CAKE	25

<b>GREETINGS FROM HUNGARY</b> INSPIRATION: DOBOS CAKE	26
<b>GREETINGS FROM AFRICA</b> INSPIRATION: MARULA CAKE	27



# Greetings from Austria



## INSPIRATION: APPLE STRUDEL

*Sweet-sour apples, juicy raisins, crunchy almonds and fragrant cinnamon combined with a classic strudel pastry, puff pastry or quark dough — and there you have apple strudel, one of Austria's most beloved pastries.*

*Our interpretation is especially appealing with its extravagant apple rosette decoration.*

*Recipe on page 12*

*Greetings from  
the USA*



**INSPIRATION:**  
**BANANA FOSTER**

*Banana Foster, or flambéed bananas, is a popular dessert in the US which supposedly originated in New Orleans.*

*Our cake and tartlet variations combine rum and vanilla accents with banana and toffee.*

*Recipe on page 13*



# Greetings from Spain



## **INSPIRATION:** **SAN MARCOS** **CAKE**

*Spain's traditional holiday cake is made of light sponge, chocolate creme and whipped cream.*

*In our variation of the San Marcos Cake, we stack three cake layers alternating with dabs of chocolate creme and whipped cream.*

*Recipe on page 14*

# Greetings from Canada



## INSPIRATION: S'MORES

*S'Mores are the beloved American and Canadian campfire treat. A shortened form of „some more“, because you just keep wanting more, this classic sweet is made with roasted marshmallows and melted chocolate sandwiched between two crisp cookies.*

*Our interpretation of s'mores in cake form, whether large or small, has additional hints of caramel and espresso!*

*Recipe on page 15*





#### Cinnamon (78704)

- sweet cinnamon bark note
- spicy-herbal cinnamon leaf finish
- natural cinnamon flavour for all cinnamon baked goods

## GREETINGS FROM

## AUSTRIA

### INGREDIENTS:

10 tartlets 8 cm Ø or  
1 cake 24 cm Ø

Ø 8	Ø 24 cm	
10	1 pcs	Shortcrust pastry base (MELLA-MÜRBI/IREKS) (8 cm bzw. 24 cm Ø), baked
80	50 g	<b>Power Filling Peach-Passionfruit</b> (32908)
20	2 pcs	Puff pastry bases (8 cm bzw. 24 cm Ø), baked
600	2.300 g	<b>Apple Filling Special</b> (37688)
30	100 g	Raisins
30	120 g	Almonds, split, roasted
10	7 g	<b>Cinnamon</b> (78704)

### TOPPING

3	3 pcs	Apples
1	1 pc	Puff pastry strip, 80 x 3 cm rolled very thin



- |    |     |   |
|----|-----|---|
| 10 | pcs | Puff pastry stripes, 50 x 3 cm rolled very thin |
| 5  | pcs | Puff pastry stripes, 30 x 3 cm rolled very thin |

### DECORATION

300	280 g	<b>Sprühfix Apricot</b> (37988)
150	50 g	Almonds, sliced, roasted

### INSTRUCTIONS:

**Baking temperature: approx. 180° C**  
**Baking time: approx. 20 / 40 Min.**

For the topping: Cut the apples into thin slices and blanch them briefly in hot water. Roll out the puff pastry and cut into thin stripes (3 cm). Place the apple slices on top and roll them up. Lay the pastry roses in a ring (8 or 24 cm diameter, see photo) and bake. Spread the shortcrust base with **Power Filling Peach-Passionfruit**, place a ring around it, and lay a puff pastry base on top. Spread half of the apple filling on top of this. Place the second puff pastry base on top and spread with the remaining apple filling. Glaze the prepared topping with **Sprühfix Apricot** and lay it on top. Decorate with almonds.

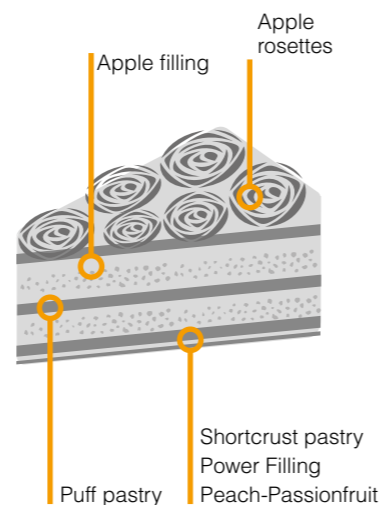

## GREETINGS FROM

## THE USA

### INGREDIENTS:

10 tartlets 8 cm Ø or  
1 cake 24 cm Ø

Ø 8	Ø 24 cm	
10	1 pcs	Shortcrust pastry base (MELLA-MÜRBI/IREKS) (8 cm bzw. 24 cm Ø), baked
100	50 g	<b>Butter Caramel</b> (45118)

### POUND CAKE BASE

375	375 g	<b>SandRühr Premium</b> (43113)
250	250 g	Water
250	250 g	Edible Oil
250	250 g	Flour
60	60 g	<b>Banana Paste</b> (20204)
10	10 g	<b>Zimtino</b> (15104)
5	5 g	<b>Butter</b> (70504)

### SYRUP

100	80 g	Simple syrup 2:1
10	10 g	<b>Rum JAMAICA Paste</b> (21904)

### FILLING

120	280 g	Banana slices, fresh
10	15 g	<b>Toffee Paste</b> (41904)
30	55 g	pecans, chopped

### VANILLA-RUM MOUSSE

50	95 g	<b>Fond Royal CL Neutral</b> (12466)
60	120 g	Water
1	10 g	<b>Rum JAMAICA Paste</b> (21904)
3	5 g	<b>Vanille Moroni Paste</b> (22004)
240	475 g	Cream, whipped, unsweetened

### DECORATION

200	400 g	Cream for decoration with <b>Stabifix F</b> (31904)
20	10 g	<b>Bienetta</b> (33518)
20	10 g	Banana chips, dried
30	50 g	<b>Butter Caramel</b> (45118)

### INSTRUCTIONS:

**Baking temperature: approx. 190° C**  
**Baking time: approx. 20 Min.**

Combine the ingredients for the pound cake base in the mixer at slow speed for 4 minutes, then spread in rings (8 cm: 2 bases, each 60 g; 24 cm: 3 bases, each 400 g). Bake. Set one or two whole banana chips aside for the garnish, then chop the rest and bake them together with the **Bienetta** (temperature: approx. 190°C, baking time: approx. 6 min). Spread the shortcrust base with **Butter Caramel** and place a pound cake

base on top. Mix the banana slices with the **Toffee Paste** and nuts, and spread 175 g (8 cm: 15 g) on the bottom layer. Prepare the vanilla-rum mousse and spread 350 g (8 cm: 35 g) on the bananas. Place the second cake layer on top, then the remaining bananas, and spread 350 g whipped cream on top. Top with third cake layer. Freeze briefly. Frost with the stabilised whipped cream and make a combed pattern. Finish garnishing with the **Bienetta** and **Butter Caramel**.

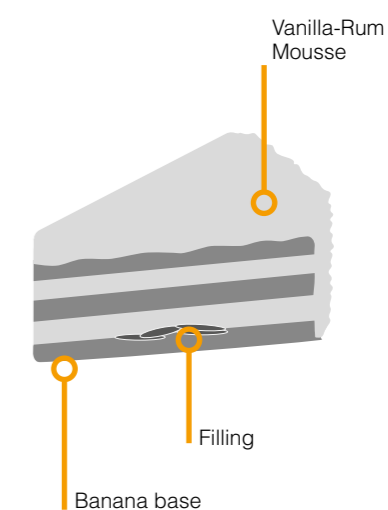

#### Banana Paste (20204)

- full, sweet, fruity flavour
- with banana pulp
- bake stable
- vegan



## GREETINGS FROM

## SPAIN

### INGREDIENTS:

10 tartlets 8 cm Ø or  
1 cake 24 cm Ø

Ø 8 Ø 24 cm

#### BASE AND TOPPING

270	200 g	<b>SandRühr Premium</b> (43113)
180	135 g	Edible Oil
180	135 g	Water
180	135 g	Flour
5	4 g	<b>Oraperl</b> (17303)
10	2 pcs	Sponge bases 8 cm bzw. 24 cm

#### VANILLA MOUSSE

70	110 g	<b>Fond Royal CL Neutral</b> (12466)
90	140 g	Water
2	3 g	<b>Vanilla PRINCESSE</b> (28006)
340	550 g	Cream, whipped, unsweetened

#### CHOCOLATE MOUSSE

70	55 g	<b>Fond Royal CL Schokolade</b> (12066)
90	70 g	Water
340	275 g	Cream, whipped, unsweetened

#### DECORATION

##### EGG GLAZE

45	45 g	Egg yolk
95	95 g	Sugar
10	10 g	<b>Crème Tradition</b> (33811)
35	35 g	Water
20	15 g	Brown Sugar
20	30 g	<b>Schokoladino</b> (36818)

### INSTRUCTIONS:

**Baking temperature: approx. 190° C**  
**Baking time: approx. 15 Min.**

Combine all ingredients for the pound cake base in the mixer at slow speed for 4 minutes, then spread in rings and bake (8 cm: 2 bases, each 40 g; 24 cm: 2 bases, each 300 g). Mix **Fond Royal CL Neutral** with water and **Vanilla PRINCESSE** and fold in whipped cream. Prepare the chocolate mousse. Pipe dabs of cream on base, alternating flavours (see picture). For the glaze: whisk the egg yolk and sugar together over a warm double-boiler. Mix the **Crème Tradition** with the water and add to the egg mixture. Allow to boil up briefly. Pour over top cake layer, sprinkle with brown sugar, and caramelize with flame. Place on cake and garnish with **Schokoladino**.

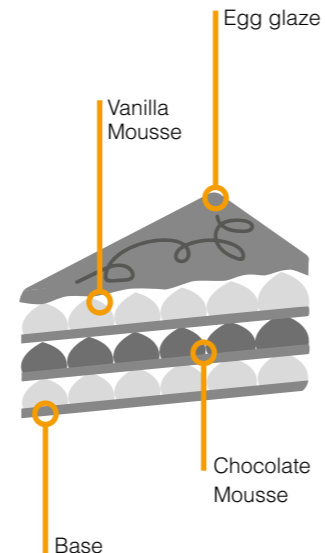

Oraperl (17303)

- fruity, fresh flavour of ripe oranges
- made from cold-pressed orange oil
- an excellent alternative to orange zest



## GREETINGS FROM

## CANADA

### INGREDIENTS:

10 tartlets 8 cm Ø or  
1 cake 24 cm Ø

Ø 8 Ø 24 cm

10	1 pcs	Shortcrust pastry base (MELLA-MÜRBI/IREKS) (8 cm bzw. 24 cm Ø), baked
100	50 g	<b>Butter Caramel</b> (45118)

#### BASE

420	715 g	<b>Sacher Mix</b> (40222)
220	360 g	Water
120	215 g	Butter
20	30 g	<b>Espresso Paste</b> (26704)
30	40 g	<b>Crème de Cacao Paste</b> (20406)
80	140 g	<b>Decor Mini Chocolate Shavings</b> (08401)

#### FILLING

50	80 g	Shortbread Biscuits
600	750 g	<b>Schogette</b> (43422)

200 340 g **Butter Caramel**  
(45118)

250 300 g **Schogette** (43422)

#### GLAZE

100	95 g	Sugar
60	55 g	Water
6	5 g	Cocoa Powder
70	60 g	Condensed Milk
70	60 g	Sanett solution
		<b>Sanett</b> (33066), see label for preparation
90	80 g	Couverture, dark
110	95 g	<b>Topglanz Plus</b> (44018)

#### MARSHMALLOW

30	15 g	Water
20	10 g	<b>Sanett</b> (33066)

70	35 g	Sugar
30	15 g	Dextrose
30	15 g	Water
30	15 g	Glucose
2	1 g	<b>Vanille BOURBON Paste</b> (21804) Starch : Powdered Sugar 1:1

100 40 g Shortbread Biscuits

### INSTRUCTIONS:

**Baking temperature: approx. 190° C**  
**Baking time: approx. 20 Min.**

Combine all ingredients for the cake layers in the mixer at slow speed for 4 minutes, then spread in rings and bake (8 cm: 2 bases, each 45 g; 24 cm: 2 bases, each 500 g). Marshmallows: boil sugar, dextrose, water and glucose together until the mixture reaches 122° C. Combine water and **Sanett** gently in a mixer,

pouring the cooled (to 100° C) sugar solution in slowly. Add **Vanilla BOURBON Paste** and whip. Dust some of the combined starch and sugar onto a baking tray and spread the cooled marshmallow mixture over it. Sprinkle with more starch-sugar mix. Let set for at least 4 hours. Cut into cubes and store in an airtight container.

Spread the shortcrust base with **Butter Caramel**, and top with a pound cake layer. Pipe **Schogette** and **Butter Caramel** in alternating rings onto the cake, and sprinkle with cookie crumbs. Repeat with the next cake layer, then top with the third cake layer and chill. Whip the remaining **Schogette** and frost cake with it. For the glaze, boil sugar, water and cocoa powder to 105° C. Mix in condensed milk, Sanett solution and couverture. Finally, fold in **Topglanz** carefully. Glaze cake. Flame marshmallows lightly and garnish cake.

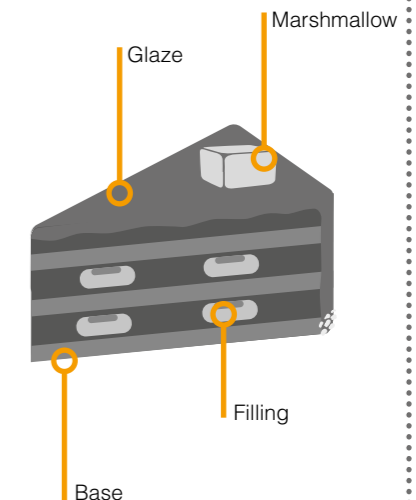

Espresso Paste  
(26704)

- with a typical espresso taste
- rounded off with a light cocoa note
- bake stable
- vegan



# Greetings from Asia



## INSPIRATION: JAPANESE CHEESECAKE

*Light and fluffy, more soufflé than cake – the Japanese, or Cotton Cheesecake is one of the hottest international trends right now!*

*We have added a hint of lemon and delicate powdered sugar decorations, making it a real eye-catcher in display cases.*

*Recipe on page 24*

*Greetings from  
Germany*



**INSPIRATION:  
BLACK FOREST  
CAKE**

*Although we don't know the exact origin of the Black Forest Cake – everyone agrees that the combination of fruity cherries, cherry brandy, moist chocolate cake layers and whipped cream is a must-have in Germany's pastry counters.*

*For our Black Forest-style cake and tartlets, we use chocolate wafers to create an elegant, striking presentation.*

*Recipe on page 25*

# Greetings from Hungary



## INSPIRATION: DOBOS CAKE

*In the late 19th century, József Dobos developed one of Hungary's best-known cakes. The original recipe consists of 8 layers of sponge cake, chocolate cream, and caramel glaze.*

*Our interpretation also features delicate cake layers and creamy chocolate buttercream.*

*Recipe on page 26*



# Greetings from Africa



## **INSPIRATION:** **MARULA FRUIT**

*The marula tree is known as the king of African trees due to its ability to produce impressive harvests with very little water. Delicious jams and liqueurs are made from the fruit, with its tart refreshing taste.*

*We have combined PASTAROM Classic Marula mit PASTAROM Paste Mango.*

*Recipe on page 27*



## GREETINGS FROM

### ASIA

#### INGREDIENTS:

10 tartlets 8 cm Ø or  
1 cake 20 cm Ø

Ø 8 Ø 20 cm

#### CHEESECAKE BATTER

170	250 g	Cream Cheese
45	70 g	Sugar
40	60 g	Butter
65	100 g	Milk
6	10 g	<b>Cream Cheese 5 Plus</b> (18804)
4	6 g	<b>Citroperl</b> (17403)
40	60 g	Flour
25	40 g	Wheat Starch
4	6 pcs	Egg yolk

#### MERINGUE

4	6 pcs	Egg whites
45	70 g	Sugar
3	4 g	Baking powder

#### DECORATION

Icing Sugar  
stencil

#### INSTRUCTIONS:

Combine cream cheese, butter, milk, **Cream Cheese 5 Plus** and **Citroperl**, then heat over a double-boiler to 45° C. Sift together flour and starch. Beat egg whites slowly together with the sugar and baking powder until the meringue is stable and smooth.

Fold the egg yolks bit by bit into the cream cheese batter, then the flour-starch mixture. Mix in 1/3 of the meringue, stirring until the batter is smooth, then carefully fold in the remaining meringue. Line the bottom of a cake tin with baking paper and grease the sides. Pour in cake batter (to max. 1,5–2 cm below top edge), and place in a water bath filled with approx. 4 cm of hot water.

Tip: place a cloth on the bottom of the water bath for insulation.

Bake at 200° C for 18 minutes. Reduce oven temperature to 140° C and bake for another 30 minutes, leaving the oven door slightly open. After 30 minutes, turn off the oven but leave the cake in for 10 minutes. After letting the cake cool slightly, remove it from the form and decorate with stenciled icing sugar motifs.

Instructions (8 cm):

Preheat oven to 120° C, and bake forms in water bath for approx. 50 minutes.

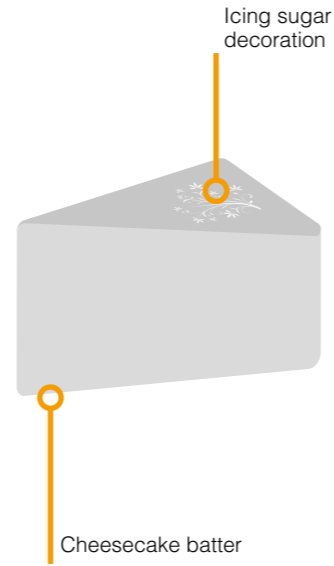

Slice „Greetings from Asia“

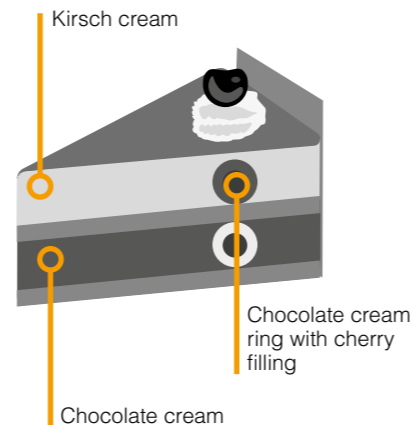

Slice „Greetings from Germany“



## GREETINGS FROM

### GERMANY

#### INGREDIENTS:

10 tartlets 8 cm Ø or  
1 cake 24 cm Ø

Ø 8 Ø 24 cm

10	1 pcs	Shortcrust pastry base (MELLA-MÜRBI/REKS) (8 cm bzw. 24 cm Ø), baked
10	2 pcs	Dark cake layers (8 cm bzw. 24 cm Ø), see label <b>Spezialmassen Mix</b> (40922)
200	210 g	Simple syrup - with <b>Cherry Brandy Paste</b> (21704)
120	130 g	<b>Power Filling Amarena-Cherry</b> (38708)

#### CHOCOLATE CREAM (CAKE)

100	100 g	<b>Fond Royal CL Chocolate</b> (12066)
125	125 g	Water
500	500 g	Cream, whipped, unsweetened

#### KIRSCH CREAM (CAKE)

100	100 g	<b>Fond Royal CL Neutral</b> (12466)
130	125 g	Water
40	40 g	<b>Cherry Brandy Paste</b> (21704)
500	500 g	Cream, whipped, unsweetened

#### KIRSCH CREAM (RING)

35 g	<b>Fond Royal CL Neutral</b> (12466)	
45 g	Water	
10 g	<b>Cherry Brandy Paste</b> (21704)	
170 g	Cream, whipped, unsweetened	
45	160 g	<b>Paradiso Fruit Delight Cherry</b> (31218)

#### CHOCOLATE CREAM (RING)

35 g	<b>Fond Royal CL Schokolade</b> (12066)
45 g	Water
180 g	Cream, whipped, unsweetened
160 g	<b>Paradiso Fruit Delight Cherry</b> (31218)

#### GLAZE

80	80 g	Cream
160	160 g	<b>Schokoladino</b> (36818)
20	20 g	Sanett solution <b>Sanett</b> (33066), see label for preparation

#### DECORATION

50 g	Cream for decoration with <b>Stabifix F</b> (31904) <b>Cherry Brandy Paste</b> (21704)
------	--

#### Chocollette Paste

(23706)  
couverture deco-plates and discs  
cherries, fresh

#### INSTRUCTIONS:

Instructions Cake (24 cm):

Form 2 rings of **Paradiso Fruit Delight Cherry** (18 cm) and freeze. Arrange the kirsch cream (ring) in the silicon ring (Silikomart FLM01B). Prepare the chocolate cream ring in the same way. Spread the shortcrust base with **Power Filling Amarena Cherry** (60 g). Place a ring around it. Then place a cake layer (about 15 mm thick) on top and soak with kirsch syrup. Spread the chocolate cream (cake) on the cake, and press the frozen kirsch cream ring into it, centering it (see diagram). Place the second cake layer on top, soak in syrup, and spread with more **Power Filling Amarena Cherry**. Spread the kirsch cream on top, press the frozen chocolate cream ring into it, smooth the surface, and chill. For the glaze, boil the cream and stir in warm **Schokoladino** and Sanett solution. Use this to glaze the top of the cake. Flavour the garnishing whipped cream with the Fine Pastry Pastes and dot top of cake with dabs of whipped cream. Place couverture sheets and discs on cake as in photo.

Instructions tartlets (8 cm): Fill **Paradiso Fruit Delight Cherry** in a spherical mould and freeze. Layering of the tartlets proceeds similarly to the larger cake, however only one frozen fruit ring is placed, namely in the bottom part of the tartlet (chocolate cream).



Cherry Brandy Paste (21704)

- distinctive taste
- with 55 % Black Forest Cherry Brandy
- for genuine classic German recipe



Citroperl (17403)

- fresh, tangy, with a light bitter note
- contains natural lemon flavour
- proven for 60 years



## GREETINGS FROM

## HUNGARY

### INGREDIENTS:

10 tartlets 8 cm Ø or  
1 cake 24 cm Ø

Ø 8 Ø 24 cm

10	1 pcs	Shortcrust pastry base (MELLA-MÜRBI/IREKS) (8 cm bzw. 24 cm Ø), baked
80	50 g	<b>Power Filling Peach-Passionfruit</b> (32908)

### DOBOS CAKE

260	470 g	<b>Spezialmassen Mix</b> (40922)
200	325 g	Water
1	3 g	<b>Trisan</b> (16604)
3	8 g	<b>Vanille Europa</b> (71904)
50	95 g	Butter, melted

### CHOCOLATE BUTTERCREAM

200	400 g	<b>Buttercream Base</b> (34611)
500	1.000 g	Water
500	1.000 g	Butter

60 120 g **Creme de Cacao Paste** (20406)

### GLAZE

10	1 pcs	Shortcrust pastry base (MELLA-MÜRBI/IREKS) (8 cm bzw. 24 cm Ø), baked (divide 8 cm in 6 wedges, 24 cm in 12)
250	250 g	<b>Butter Caramel</b> (45118)
65	65 g	Sanett solution <b>Sanett</b> (33066), see label for preparation
10	50 g	<b>Decor Chocolate Flakes</b> (97201)

### INSTRUCTIONS:

**Baking temperature: approx. 210° C**  
**Baking time: approx. 8 / 6 Min.**

To prepare the Dobos cake layers, beat **Spezialmassen Mix**, water and flavourings for 5–7 minutes at fast setting, then fold in melted butter. Spread batter among 9 24-cm (or 5 8-cm), bake and cool.

Combine **Buttercream Base** with water. Beat softened butter until fluffy. Fold the cold cream and **Creme de Cacao** slowly into the butter, then beat all together.

Spread shortcrust base with 250 g **Power Filling Peach-Passionfruit** (8 cm: 25 g), top with a cake layer. Spread with cream. Place the next cake layer on top, spread with cream; repeat these steps until 9 layers (8 cm: 5 layers) have been used. Set aside to chill.

Frost the cake with the remaining cream, including pipee rosettes on top.

Mix **Butter Caramel** with the warmed Sanett solution and pour over the shortcrust wedges. When cooled, place wedges on the rosettes and sprinkle chocolate bits around base of cake.

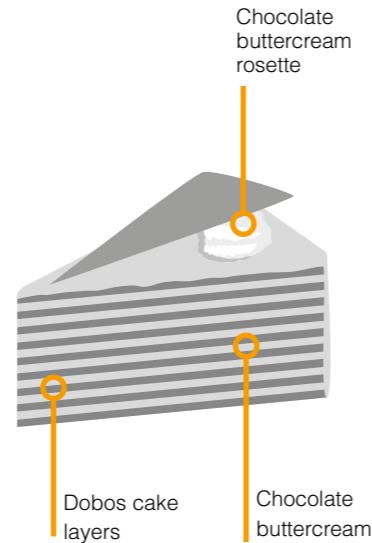

## GREETINGS FROM

## AFRICA

### INGREDIENTS:

10 tartlets 8 cm Ø or  
1 cake 24 cm Ø

Ø 8 Ø 24 cm

10	1 pcs	Shortcrust pastry base (MELLA-MÜRBI/IREKS) (8 cm bzw. 24 cm Ø), baked
80	50 g	<b>Power Filling Peach-Passionfruit</b> (32908)

### DARK CAKE LAYERS

300	340 g	<b>Spezialmassen Mix</b> (40922)
220	275 g	Water
30	35 g	Butter, melted
40	48 g	<b>Creme de Cacao Paste</b> (20406)
8	10 g	<b>Cake Flavour Europa</b> (77104)

### MARULA MOUSSE

10	15 g	<b>PASTAROM Classic Marula</b> (78104)
----	------	--

60	85 g	Sanett solution <b>Sanett</b> (33066), see label for preparation
500	700 g	Cream, whipped, sweetened

### MANGO TYPE MOUSSE

30	40 g	<b>PASTAROM Paste Mango H</b> (67440)
60	80 g	Sanett solution <b>Sanett</b> (33066), see label for preparation
500	680 g	Cream, whipped, sweetened

### DECORATION

50	50 g	Cream for decoration with <b>Stabifix F</b> (31904)
20	10 g	Mangocubes
80	30 g	Pistachios, chopped Mangoslices Red currants

### GLAZE

50	50 g	Water
100	95 g	Sugar
100	75 g	Glucose syrup
50	60 g	Condensed Milk
100	90 g	Sanett solution <b>Sanett</b> (33066), see label for preparation
150	130 g	Couverture, white
4	4 g	<b>PASTAROM Paste Marula</b> (78104)
20	20 g	<b>PASTAROM Paste Mango H</b> (67440)

### INSTRUCTIONS:

**Baking temperature: approx. 220° C**

**Baking time: approx. 7 Min.**

Beat **Spezialmassen Mix** with water. Combine melted butter with the **Creme de Cacao Paste** and **Cake**

**Flavour Europa** and mix into cake batter. Spread into rectangles (8 cm: 32 x 6 cm; 24: 60 x 40 cm). Bake. Cut cooled cake into stripes (8 cm: 30 x 5 cm; 24 cm: 60 x 9 cm). Spread shortcrust base with **Power Filling Peach-Passionfruit**. For the Marula Mousse: Mix together Sanett solution and **PASTAROM Classic Marula**, fold in whipped cream. Prepare Mango Mousse in the same way. Spread the mousses alternately in thin layers on the cake stripes. Place stripes in a spiral pattern on the shortcrust base. Freeze for at least 2 hours. Frost with stabilised whipped cream, freeze again briefly. For the glaze: Boil water, sugar and glucose syrup together to 110° C. Add condensed milk, couverture and Sanett solution. Flavour 400 g (8 cm: 45 g) with **PASTAROM Paste Mango H**, and the remaining glaze with **PASTAROM Classic Marula**. Pour the yellow glaze over the cold cake with a spoon. Leaving a bit of the yellow glaze on the spoon, put some of the brown glaze on top of it and pour carefully over the cake (see photo). Garnish with whipped cream, pistachios and fruits.

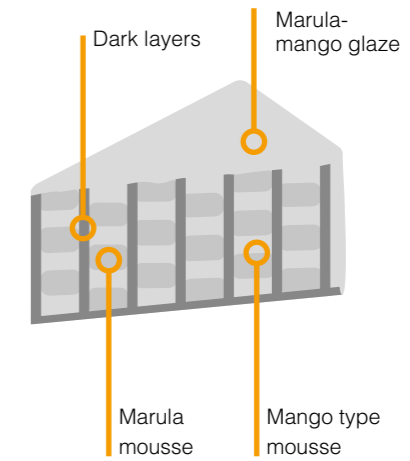

### PASTAROM Classic Marula (78104)

- liqueury chocolate taste
- fruity rounded
- brown colour
- vegan



Creme de Cacao Paste (20406)

- strong full-bodied flavour
- with 40 % cocoa powder
- vegan

## MODERN IN TRADITION

Since 1899, we have been the specialist for the development and production of fruity and sweet flavourings. As a traditional company with nearly 12 decades of experience, we understand better than nearly anyone how to combine traditional craft with modern inspiration

### FROM LANGENFELD INTO THE WORLD

Our extensive product range, from cream stabilisers to baking mixes to flavourings and pastry pastes, lightens daily operations in bakeries and confectioneries, and is exported from Langenfeld (Rheinland) all over the world.

### OUR CORE COMPETENCE: TASTE

With over 80 different pastry pastes and flavourings – from classic to trendy – we provide you with subtly balanced flavour nuances and characteristic colours for the preparation of custom creations, from delicate cakes to efficient traybakes.

Dreidoppel – Ideas for good taste! Since 1899.

DISCOVER OUR PRODUCT RANGE FOR MORE CREATIVITY IN BAKERIES,  
PASTRY SHOPS AND ICE-CREAM PARLOURS  
AT [WWW.DREIDOPPEL.DE](http://WWW.DREIDOPPEL.DE)